

Owner's Manual

READ THIS MANUAL CAREFULLY,
IT CONTAINS IMPORTANT SAFETY INFORMATION.

TBM150

**MINIMUM
RECOMMENDED
OPERATOR AGE: 16**



FOR OFF-ROAD USE ONLY

This vehicle is designed and manufactured for off-road use only.

USA only:

It does not conform to Federal Motor Vehicle Safety Standards, and in regards to operation on public streets, roads, or highways is illegal.

BV Powersports, LLC – EMISSION CONTROL SYSTEM WARRANTY

This document describes the detailed warranty information for the emission control system on the 2011 Off-Road UTV. It is important to note that all procedures strictly follow standards outlined by the U.S. Environmental Protection Agency (EPA) and the California Air Resources Board (CARB).

BV Powersports, LLC (hereinafter as importer) warrants that each new 2011 and later import off-road vehicle:

A. is designed, built and equipped so as to conform at the time of initial retail purchase with all applicable regulations of the United States Environmental Protection Agency, and the California Air Resources Board; and

B. is free from defects in material and workmanship which cause such vehicle to fail to conform to applicable regulations of the United States Environmental Protection Agency or the California Air Resources Board for the periods specified above.

All new off-road motor vehicles have been designed and built to meet the higher emission standards, and hence the emission control system will be warranted to cover 10,000 km, 1,000 hours of engine operation, or five years after the vehicle is sold, whichever comes first. Importer and/or distributors will repair your vehicle including diagnosis, parts, and labor, at no cost to you. The warranty period commences on the date the vehicle is delivered to the initial retail purchaser, or when the vehicle is first placed in service as a demonstrator, rental, and lease prior to retail sale.

Your emission control system may include parts such as carburetor or fuel injection system, ignition system, catalytic converter, and engine computer, if they are equipped. Also included may be hoses, belts, connectors, as well as other emission-related assemblies.

As part of the emission control system defects warranty, if an emission-related part on your vehicle is defective, the part will be repaired or replaced by any authorized distributors once the vehicle is presented to them.

OWNER'S WARRANTY RESPONSIBILITIES

As a vehicle owner, you are responsible for all the required scheduled maintenances listed in your owner's manual. It is recommended that you keep records of all receipts and other supporting documents covering services on your vehicle in order to receive proper warranty of your vehicle. But distributors cannot deny warranty solely for the lack of receipts or for your failure to ensure the performance of all scheduled maintenance.

You are responsible for presenting your vehicle to any authorized distributors promptly after any emission control related problems occur. The warranty replacements or repairs should be completed in a timely matter, typically not to exceed 30 business days.

As the vehicle owner, you should also be aware that any authorized distributors may deny your

warranty coverage if your vehicle or any parts have failed due to personal abuse, neglect, improper maintenance, or unapproved modifications. In particular, this Emission Control System Warranty shall not cover any of the following:

A. Repair or replacement as a result of:

- (1) Accident,
- (2) Misuse,
- (3) Repairs improperly performed or replacements improperly installed by unauthorized personnel,
- (4) Use of replacement parts or accessories not conforming to specifications set forth by distributors, which could adversely affect performance and/or,
- (5) Use in competitive racing or related events.

B. Replacements of parts, other services, and adjustments for improper maintenance.

C. Any vehicle equipped with an odometer or hour meter on which the odometer mileage or hour meter reading has been modified so that actual mileage cannot be readily determined.

This Limited Emission Control System Warranty statement is issued by the importer. No distributor is authorized to make any corrections to this statement.

ORDER PARTS

<https://gokartsusa.com/TrailMaster-150-XXR-Gokart-Parts.aspx>

ORDERS



(707) 745-5278

CONTENTS

OWNER' S MANUAL

Page

1. FOREWORD	1
2. A FEW WORDS ABOUT SAFETY	2
3. IMPORTANT SAFETY INFORMATION	3
4. SAFETY LABELS	5
5. ARE YOU READY TO DRIVE ?	6
6. SAFE DRIVING PRECAUTIONS	8
7. P.D.L.....	10
8. SPECIFICATIONS	11
9. OPERATION	13
10. OPERATION/SERVICE INSTRUCTIONS.....	17
11. SERVICE INSTRUCTIONS.....	18
12. REPAIR.....	21
13. PERIODICAL CHECK AND SERVICES	23

PARTS MANUAL

Fig

1. CYLINDER HEAD ASSY.....	Fig. 1
2. CYLINDER ASSY.....	Fig. 2

FOREWORD

Thank you for purchasing our Kart. We hope you will enjoy it. Before you start to operate the Kart, please read through this Owner's Manual carefully as it contains important safety and maintenance information. Failure to follow the warnings contained in this manual can result in serious injuries or death.

Be sure to follow the recommended maintenance schedule and service your kart accordingly. Preventive maintenance is extremely important to the longevity of your Kart.

Beginners should seek instructions from your dealer or qualified instructors before and during initial use of the kart. It is also recommended to practice in a large open area and familiar with operations of this kart.

We hope you will have a pleasant experience with our products and thanks again for choosing our Kart.

ORDER PARTS

<https://gokartsusa.com/TrailMaster-150-XXR-Gokart-Parts.aspx>

ORDERS



(707) 745-5278

A FEW WORDS ABOUT SAFETY

In order to keep everyone safe, you must take responsibility for the safe operation of your Kart.

To help you make informed decisions about safety, we have provided operating procedures and other information on labels and in this manual. This information alerts you to potential hazards that could hurt you or others.

It is not practical or possible to warn you about all hazards associated with operating or maintaining a Kart. You must use your own good judgment.

You will find important safety information in a variety of forms, including:

Safety Labels – On the Kart.

Safety Messages – Preceded by a safety alert symbol  and one of two signal words: **WARNING**, or **CAUTION**.

These signal words mean:



Physical harm may result from failure to adhere to the instructions that are described within the **WARNING** labels.

Safety Headings — such as Important Safety Reminders or Important Safety Precautions.

Safety Section — such as Kart Safety.

Instructions — how to use this Kart correctly and safely.

This entire manual is filled with important safety information—please read it carefully.

IMPORTANT SAFETY INFORMATION

Your Kart will provide you with many years of service and pleasure. Providing you take responsibility for your own safety and understand the challenges you can meet while driving.

There is much that you can do to protect yourself while operating your kart. You'll find many helpful recommendations throughout this manual. The following are a few that we consider most important.

Follow the Age Recommendation

Adult Supervision should be present for all people under the age of 16.

Always Wear a Helmet

It's a proven fact: helmets significantly reduce the number and severity of head injuries. Always wear an approved motorcycle helmet. We also recommend that you wear eye protection, sturdy boots, gloves, and other protective gear.

Drive Off-Road Only

Your Kart is designed and manufactured for off-road use only. The tires are not made for pavement, and the Kart does not have turn signals and other features required for use on public roads. If you need to cross a paved or public road, get off and walk your Kart across.

Take Time to Learn & Practice

Even if you have driven other Karts, take time to become familiar with how this Kart works and handles. Practice in a safe area until you build your skills and get accustomed to this Kart's size and weight.

Because many accidents involve inexperienced or untrained drivers, we urge all drivers to take a training course approved by the Go-Kart Safety Institute. Check with your dealer for more information on training courses.

Be Alert for Off-Road Hazards

The terrain can present a variety of challenges when you drive off-road. Continually "read" the terrain for unexpected turns, drop-offs, rocks, ruts, and other hazards. Always keep your speed low enough to allow time to see and react to hazards.

IMPORTANT SAFETY INFORMATION

Drive within Your Limits

Pushing limits is another major cause of Kart accidents. Never drive beyond your personal abilities or faster than conditions warrant. Remember that alcohol, drugs, fatigue, and inattention can significantly reduce your ability to make good judgments and drive safely.

Don't Drink and drive

Alcohol and driving don't mix. Even one drink can reduce your ability to respond to changing conditions, and your reaction time gets worse with every additional drink. So don't drink and drive, and don't let your friends drink and drive either.

Do not operate this Kart at night.

Dark vision can greatly reduce a driver's visibility and judgment. So driving at night is dangerous and can increase the possibility for an accident.

Never run your Kart indoors.

The exhaust from the engine contains a tasteless, odorless and poisonous gas called carbon monoxide.

Keep away from moving parts of the Kart

The operator of the Kart should never place their hands or other parts of their body near any moving part of the Kart. Failure to adhere to this warning will cause physical harm to your body.

Skidding or Sliding

The terrain surface can be a major factor affecting turns. Skidding in a turn is more likely to occur on slippery surfaces such as snow, ice, mud and loose gravel. If you skid on ice, you may lose all directional control. To avoid skidding on slippery terrain, keep your speed low and drive carefully.

SAFETY LABELS

This section presents some of the most important information and recommendations to help you drive your Kart safely. Please take a few moments to read these pages.

The labels should be considered permanent parts of the Kart. If a label comes off or becomes hard to read, contact your dealer for warning label replacements.

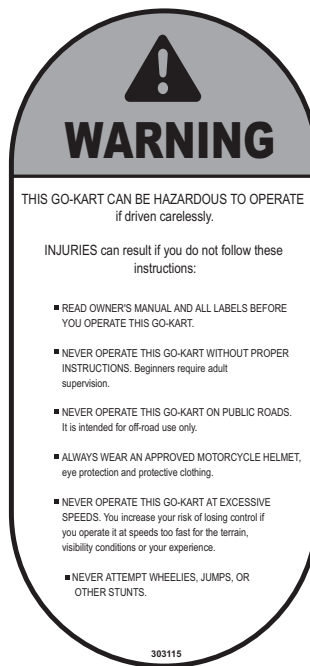

ARE YOU READY TO DRIVE ?

Before each drive, you need to make sure that you and your kart are both ready to drive. To help get you prepared, this section discusses how to evaluate your driving readiness, what items you should check on your kart, and adjustments to make for your comfort, convenience, or safety.

Before you drive your kart for the first time, we urge you to:

- Read this owner's manual and the labels on your kart carefully.
- Make sure you understand all the safety messages.
- Know how to operate all the controls.

Before each drive, be sure:

- You wear your seat belt at all times while driving your kart.
- You feel well and are in good physical and mental condition.
- You are wearing an approved motorcycle helmet (with chin strap tightened securely), eye protection, and other protective clothing.
- You don't have any alcohol or drugs in your system.

Protective Apparel

For your safety, we strongly recommend that you always wear an D.O.T. approved motorcycle helmet, eye protection, boots, gloves, long pants, and long-sleeved shirt or jacket whenever you drive.

Although complete protection is not possible, wearing proper gear can reduce the chance of injury should you have an accident.

The following suggestions will help you choose the proper protective gear.

Helmets and Eyes Protection

Your helmet is your most important piece of protective gear because it offers the best protection against head injuries. A helmet should fit your head comfortably and securely.

An open-face helmet offers some protection, but a full-face helmet offers more. Regardless of the style, look for a D.O.T. (Department of Transportation) sticker on any helmet you buy. Always wear a face shield or goggles to protect your eyes and help your vision.

WARNING

Operating this kart without wearing an approved motorcycle helmet, eye protection, and protective clothing could increase your chances of head and/or eye injury, and the possibility of death in the event of a severe accident.

Always wear an approved motorcycle helmet that fits properly and wear eye protection (goggles or face shield), gloves, boots, long-sleeved shirt or jacket and long pants.

ARE YOU READY TO DRIVE ?

Additional Driving Gear

In addition to a helmet and eye protection, we also recommend:

Sturdy off-road motorcycle boots to help protect your feet, ankles, and lower legs.

Off-road motorcycle gloves to help protect your hands.

Driving pants with knee and hip pads, a driving jersey with padded elbows, and a rider protector.

Driver Training

Developing your driving skills is an on-going process. Even if you have driven other karts, before take time to become familiar with how this kart works and handles. Practice driving the kart in a safe area to develop your skills. Do not drive on rough terrain until you get accustomed to the kart's controls, and feel comfortable with its size and weight.



Operating this kart without your seat belt could cause you to be thrown from the kart, causing serious injury or death.

No Alcohol or Drugs

Alcohol, drugs and karts don't mix. Even a small amount of alcohol can impair your ability to operate a kart safely. Likewise, drugs—even if prescribed by a physician—can be dangerous while operating a kart. Consult your doctor to be sure it is safe to operate a vehicle after taking medication.



Operating this kart after consuming alcohol or drugs can seriously affect your judgment, cause you to react more slowly, affect your balance and perception, and could result in serious injury or death.

Never consume alcohol or drugs before or while operating this kart.

IS YOUR VEHICLE READY TO DRIVE?

Before each drive, it is important to inspect your kart and make sure any problems you find are corrected. A pre-drive inspection is a must, not only for safety, but because having a breakdown, or even a flat tire, can be a major inconvenience.

If your kart has overturned or has been involved in a collision, do not drive it until your kart has been inspected by your dealer. There may be damage or other problems that you can not see.



Improperly maintaining this kart or failing to correct a problem before driving can cause a crash in which you can be seriously hurt or killed.

Always perform a pre-drive inspection before every drive and correct any problems.

SAFE DRIVING PRECAUTIONS

Off-Road Use Only

Your kart and its tires are designed and manufactured for off-road use only, not for use on paved surfaces. Driving on paved surfaces can affect the kart handling and control.

WARNING

Operating this kart on paved surfaces may seriously affect handling and control of the kart, and may cause the vehicle to go out of control.

Never operate the kart on any paved surfaces, including sidewalks, driveways, parks lots and streets.

When driving off-road, also remember to always obey local off-road driving laws and regulations. Obtain permission to drive on private property. Avoid posted areas and obey "no trespassing" signs.

You should never drive your kart on public streets, roads or highways, even if they are not paved. Drivers of street vehicles may have difficulty seeing and avoiding you, which could lead to a collision.

WARNING

Operating this kart on public streets, roads or highways could cause a collision with another vehicle.

Never operate this kart on any public streets, roads or highways, whether they are dirt, gravel or paved surfaces.

Keep Hands and Feet on Controls

When driving your kart, always keep both hands on the steering wheel and both feet on the foot controls. It is important to maintain your balance and to control the kart. Removing hands or feet away from the controls can reduce your ability to react and control the kart.

WARNING

Removing your hands from the steering wheel or feet from the foot controls during operation can reduce your ability to control the kart or could cause you to lose your balance and fall off the kart.

Always keep both hands on the steering wheel and both feet on the foot controls of your kart during operation.

SAFE DRIVING PRECAUTIONS

Control Speed

Driving at excessive speed increases the chance of an accident. In choosing a proper speed, you need to consider the capability of your Kart, the terrain, visibility and other operating conditions, plus your own skills and experience.



WARNING

Operating this Kart at excessive speeds increases your chances of losing control of the Kart, which can result in an accident.

Always drive at a speed that is proper for your Kart, the terrain, visibility and other operating conditions, and your experience.

Use Care on Unfamiliar or Rough Terrain

Before driving in a new area, always check the terrain thoroughly. Don't drive fast on unfamiliar terrain or when visibility is limited. (it's sometimes difficult to see obstructions like hidden rocks, bumps, or holes in time to react.)



WARNING

Failure to use extra care when Operating this Kart on unfamiliar terrain could result in the Kart overturning or going out of control.

Go slowly and be extra careful when operating on unfamiliar terrain. Always be alert to changing terrain conditions when operating the Kart.

Never drive past the limit of visibility. Maintain a safe distance between your Kart and other off-road vehicles. Always exercise caution and use extra care on rough, slippery and loose terrain.



WARNING

Failure to use extra care when operating on excessively rough, slippery or loose terrain could cause loss of traction or vehicle control, which could result in an accident, including an overturn.

Do not operate on excessively rough, slippery or loose terrain until you have learned and practiced the skills necessary to control the Kart on such terrain. Always be especially cautious on these kinds of terrain.

Do Not Perform Stunts

You should always operate your Kart in a safe and reasonable manner. When driving, always keep all four wheels on the ground.



WARNING

Attempting wheelies, jumps, and other stunts increases the chance of an accident, including an overturn.

Never attempt stunts, such as wheelies or jumps. Don't try to show off.

P.D.I.

- a. Install RR. Shocks and tighten the nuts.
- b. Install Ball Head, Tie Rod, tighten the Castle Nut and insert the cotter Pin.
- c. Install Dust Seals, align the Ball Head Bolt, Knuckle Support to the square hole on the Lower A-Arm.
- d. Install Flange Nut and tighten it (> 88.9 foot lbs)
- e. Install Front Tires and tighten the nuts.
- f. Install Rear Tires, tighten the nuts, insert cotter Pin and put on the Rubber Cover.
- h. Install C.B.C custom bar cage RR., put on R-Washer.
- i. Install Head-Rest.
- j. Check all nuts and bolts, wiring, cables, fuel line, switches and tire pressure.
- k. Fill battery with Acid and charge, check and fill the engine with the recommended oil.
- l. Fill fuel tank with Unleaded Gasoline, and turn on the ignition switch to start the engine.

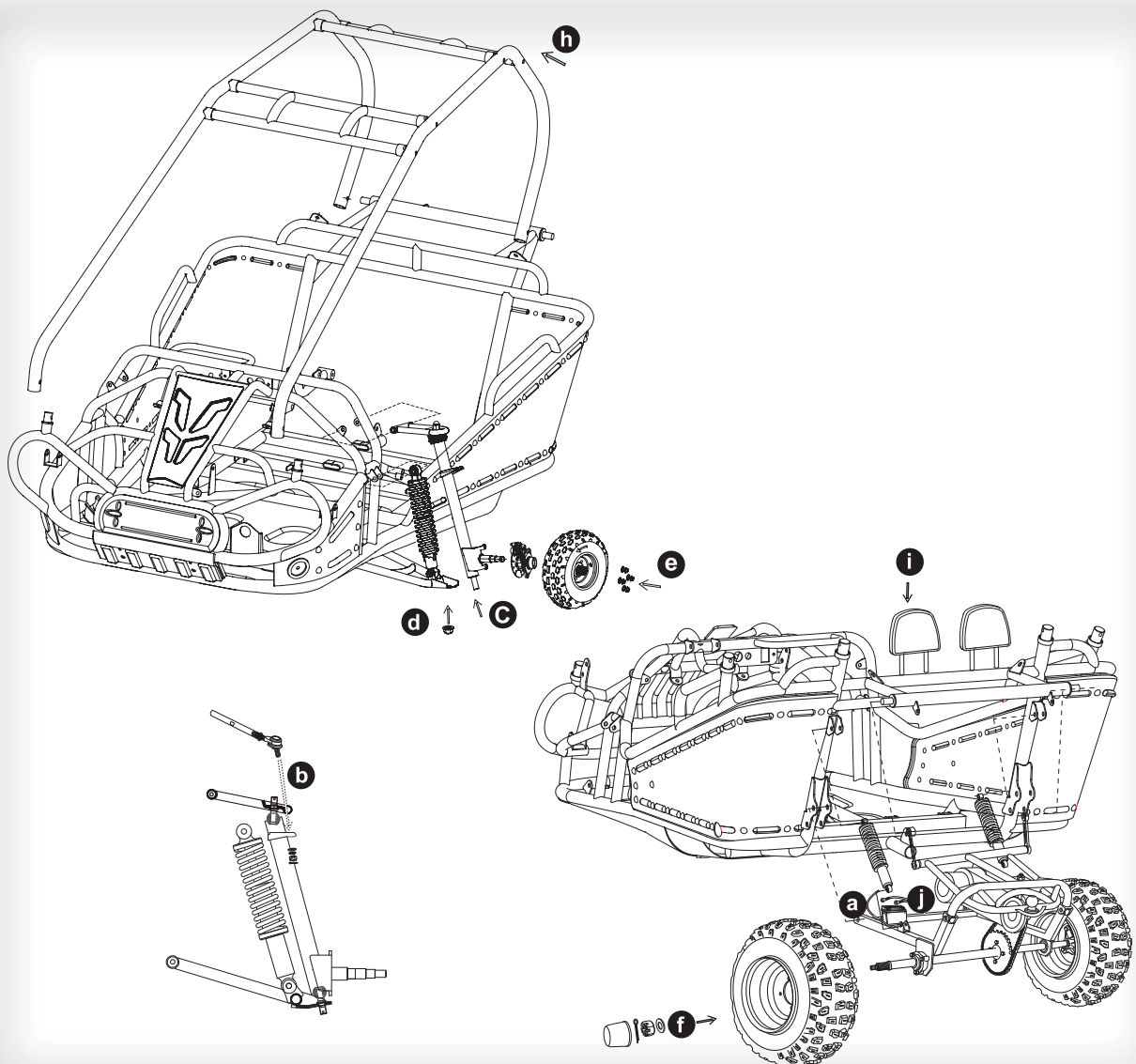

SPECIFICATIONS

DIMENSIONS

Overall Length -----	85 in. (2160mm)
Overall Width -----	53 in. (1346mm)
Overall Height -----	57.4 in. (1458mm)
Wheelbase -----	59 in. (1500mm)
Front Track -----	45.7 in. (1160mm)
Rear Track -----	39.4 in. (1000 mm)
Ground Clearance -----	6.7 in. (170mm)

ENGINE

Type -----	Forced air-cooled. 4-Stroke
Engine capacity -----	150cc
Bore / Stroke -----	57.4mm x 57.8mm
Displacement -----	149.6cm ³
Corrected compression ratio -----	9.5:1
Carburetor -----	PD24J
Output Power -----	6.4Kw/7000rpm
Maximum Torque -----	9.5/6000r/min
Starting -----	Electric
Ignition -----	C.D.I.
Lubrication -----	Force & Splash
Transmission -----	Automatic (C.V.T system)
Spark plug -----	CR7HSA(NGK)
Plug gap -----	0.7-0.8mm
Fuel Type -----	RQ90 (unleaded)
Lubricate oil -----	SAE-15W/40

CAPACITIES

Maximum load-----	Double Seats/400lbs
Fuel tank -----	1.75 Gal
Engine oil -----	30 Oz
Starting -----	<5s
Climbing -----	20 -25
Battery -----	12V 10Ah
Head Light -----	12V 35W/35W
Tail Light -----	12V 21W/5W
Fuse -----	10A

SPECIFICATIONS

Brake Track ----- < 7 m@20miles/h
Top speed ----- 30 miles/h(or limited as customers require)

CHASSIS

Front, Rear brake ----- Hydraulic disc, left foot control
Front tire ----- 20 x 7-8
Rear tire ----- 22 x 10 -10
Front Suspension ----- Independent Dual A-Arm
Rear Suspension ----- Swing Arm/Double Oil Damped Shock
Restraint System ----- Dual 4-point Harness
Final Drive Chain ----- (KMC) O-Ring Chain

TIRE PRESSURE

Front ----- 8 psi
Rear ----- 8 psi

WEIGHT

Net Weight ----- 465 lbs

A. Operation controls

WARNING - Do not attempt to start or operate the engine until completely familiar with the location and use of each control necessary to operate this vehicle. The operator must know how to stop this machine before starting and driving it.

a. Throttle

The right foot pedal is the throttle that controls the Kart speed. As the engine speed increased above idle, the clutch automatically engages and moves the vehicle forward. To disengage the clutch at any time, allow the throttle to return to the idle position.

(See Fig. 1)

WARNING

Each time prior to starting the engine, check the throttle assembly to ensure that when the pedal is pushed all the way forward the assembly is working smoothly and returns to idle when released. Do not operate if pedal or engine throttle linkage fail to return to idle. If unable to correct the problem through lubrication, adjustment or replacement of worn parts, contact your dealer for assistance.

b. Brake

The brake is located on the left side of the kart (See Fig.1). Applying pressure to the pedal draws the brake caliper around the brake pump at the rear wheel and slows or stops the kart.

c. Start engine

Insert the key into key-switch, turn the key clockwise, release the key when the engine starts. The engine will warm up within 5 minutes and the engine choke will close automatically and operate at the normal RPM (Warning: Don't crank starter more than 5 seconds at one time).

d. Engine stop button

Important-stop button test.

Before driving this vehicle, test the Engine Stop Button to assure that it is operating properly. With the engine running, push and hold the Engine Stop Button for two seconds for the engine to shut down.

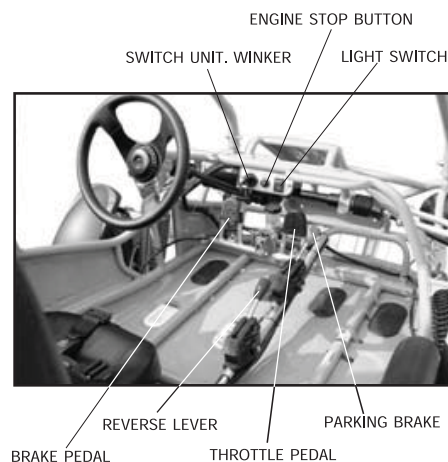

Figure 1

OPERATION

B. Pre-Drive Inspection

WARNING

Perform this pre-drive inspection everyday before driving vehicle. If not performed, serious damage to the vehicle or personal injury may result.

- a. Check for Engine Oil Level. Check for leaks, add oil if required.
- b. Check for Fuel Level. Add fuel as necessary and do not overfill. Check for leaks.
- c. Check for Brakes. Depress the rear brake pedal several times, then check for proper brake pedal freeplay. Make sure there is no brake fluid leakage. Adjust if necessary.
- d. Check Tires. Check tires condition and pressure. The pressure on both Front and Rear tire is 5 and 8 lbs respectively.
- e. Check Drive Chain. Check for drive chain's condition and tension. Lubricate if necessary.
- f. Check Throttle. Check for smooth operation. Assure throttle "snaps" back to idle.
- g. Check Engine Stop Button. Perform engine stop button test. Repair as necessary.
- h. Check all Nuts, Bolts, and fasteners. Check wheels to see that all axle nuts and lug nuts are tightened properly. Check and tighten as necessary all other fasteners to specified condition.
- i. Check C.B.C Bar. Ensure all protective C.B.C bars are in place before operating the Kart.
- j. Check Brake Light. Check for proper operation.
- k. Check Wheels. Check for tightness of wheel nuts and axle nuts; check that axle nuts are secured by cotter pins.
- l. Check Steering. Check for free operation for any unusual looseness in any area.

CAUTION

Always follow rules for safe operation and wear a helmet.

Component locations

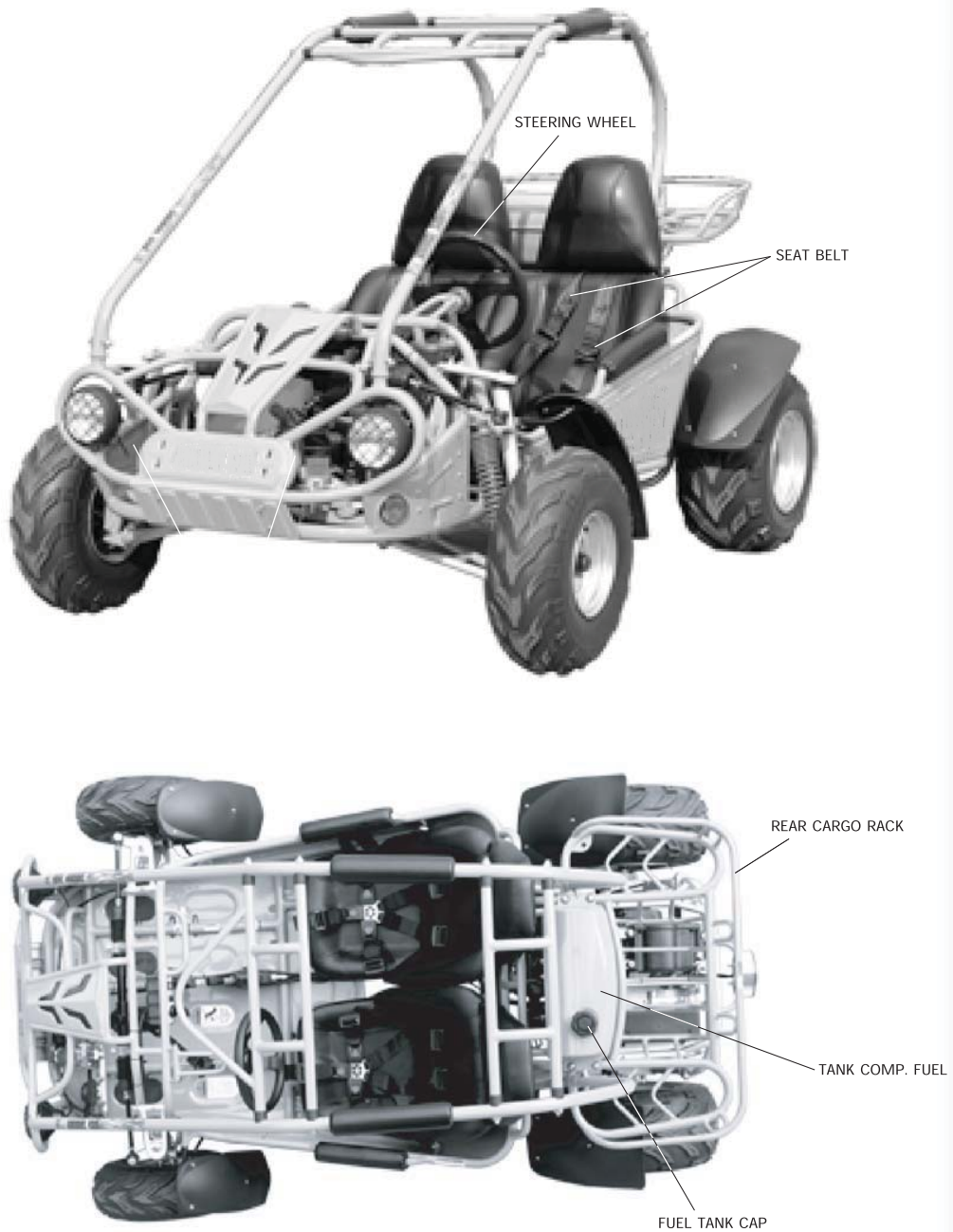

Figure 2

OPERATION

C. Passengers

The vehicle allows for two riders only. Combine maximum weight of driver and the passenger should not exceed 180kg or 400lbs.

D. Seat Adjustment

The seat must always be securely fastened in the position which best affords the operator control of the foot pedals, steering wheel, and the remote stop button.

- Pull seat adjustment handle upward to disengage seat slide.
- Move seat to desired position.
- Be sure seat adjustment handle snaps back into place and that seat is locked into position.

Figure 3



Before attempting to adjust the seat, ensure that kart engine is stopped.



Never operate this Kart when the provided seat is not securely fastened, to do so could result in a strong possibility of severe personal injury or loss of life. Before attempting to adjust the seat, ensure the kart engine is stopped.

E. Reverse Adjustment

a. Push forward the reverse lever to the "D" position so that the unit can move forward, pull back the lever to "R" so that the unit can move backward. (See Fig.4)

b. When reverse lever is in the drive position, there need to be 1/2 inch of freeplay in the reverse level. If the adjustment is not correct, then loosen the lock nut #2, then adjust lock nut #1 to the proper amount of freeplay.

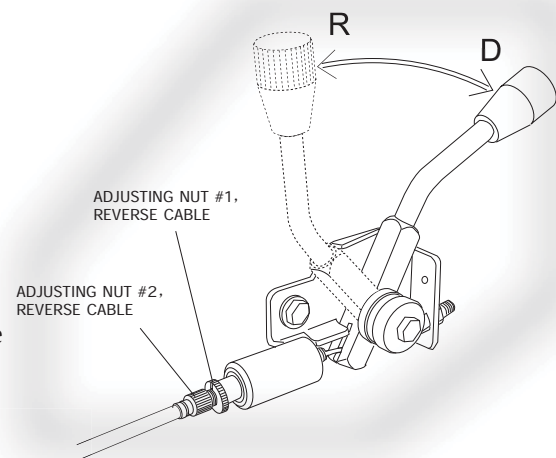

Figure 4

Always stop the kart before changing gears.

OPERATION/SERVICE INSTRUCTIONS

F. Starting And Operating Instructions

- a. Before starting the engine, be sure that the driver is seated properly in the Kart with the seat belt.
- b. Testing the Kart in an open space at the beginning to learn how to start, turn and stop.
- c. Operate the Kart slowly until you are familiar with it.
- d. The turning radius of this Kart is small and agile, so the centrifugal force is very high when turning at high speed. Slow down to a more controllable speed when turning to prevent the Kart from rolling over.
- e. To prevent vehicle from rolling over, be sure to only turn the vehicle at a slow more controllable speed. Heel on the ramp of the main board when turning. (See Fig.5) Keep your leg rely on the foot pedal, you can feel the kart is stable because of the gravity is adjusted and won't roll over.



Figure 5

SERVICE INSTRUCTIONS

A. Service Air Cleaner

Service air cleaner every 20 hours

NOTE: Service more often under dusty conditions.

- a. Remove cleaner cover
- b. Remove air cleaner element 2 (See Fig.6)
- c. Fill the non-flammable cleaning agent into a basin and dip the element in it.
- d. Dry it after cleaning.

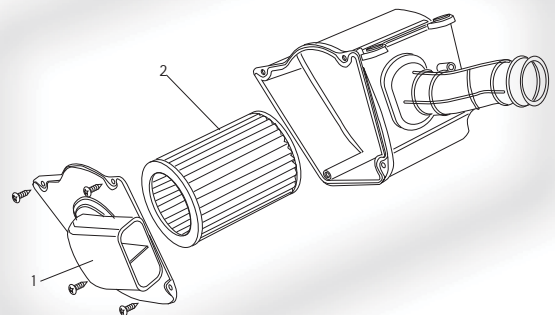

Figure 6

SERVICE INSTRUCTIONS

B. Engine Lubrication

You must change the oil in the crankcase after the first 5 hours of operating of your new engine (See Fig. 7) and after 10 hours of use thereafter. That will insure proper lubrication of internal parts and prevent costly repairs due to excessive wear.



WARNING

Used Oil Must Be disposed of at a proper collection Center

- Remove drain plug located on the right rear side of engine. Tip kart backwards slightly by blocking up the front end and drain oil into suitable container.
- Remove and clean Oil Screen.
- Replace drain plug and tighten securely. Place kart in a level position.
- Refill crankcase (approximately 1 1/4 pint) to top of filler neck with SAE 10W40 oil. Use same grade of oil as used originally.
- Check oil level before each use of kart or after each 10 hours of operation. Add oil to bring up to proper level. Do not mix various grades of oil.

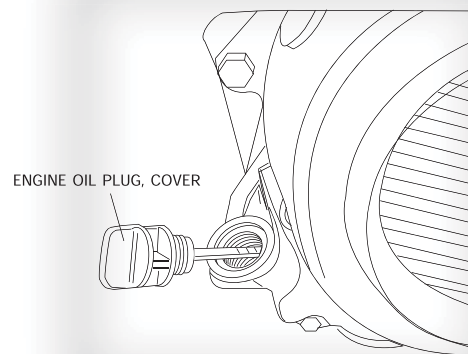

Figure 7

C. Spark Plug

- Remove the spark plug and inspect it each time you change the oil. (Use a spark plug wrench) The electrodes should be kept clean and free of carbon. The presence of carbon or excess oil will greatly reduce proper engine performance. If possible, check the spark plug gap (area between electrodes) using a wire feeler gauge. This specification is 0.7~0.8mm.
- Before installing spark plug coat threads lightly with graphite grease if possible, to ensure easy removal next time the spark plug needs inspection.
- It is advisable to replace the spark plug at least once a year to insure easy starting and good engine performance.

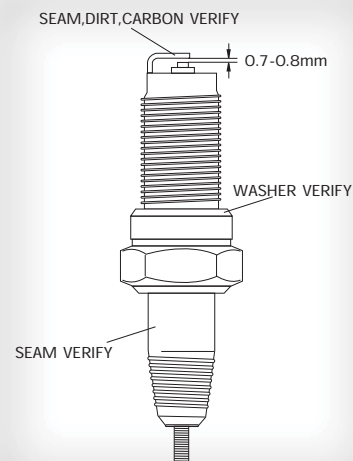

Figure 8

D. Carburetor Adjustment

Never make unnecessary adjustments. The factory recommended settings are correct for most applications.

SERVICE INSTRUCTIONS

- a. Warm up the engine (5~10min)
- b. Tighten the air screw gently. Backout 2-3/8 turns counter clockwise.
- c. Connect the tachometer, adjust the throttle to limit the idle speed. The standard value is (1400RPM).
- d. Turn the air screw counter clockwise slowly and observe the RPM of the engine, stop adjusting as the RPM reaches the top speed.
- e. Adjust the screw and adjust the idle speed to an ideal value.
- f. Recheck and readjust the idle speed if necessary.

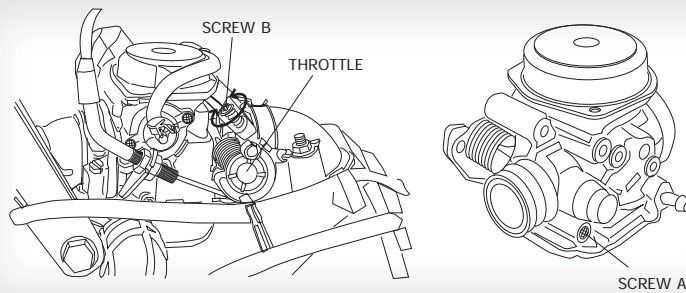

Figure 9

E. Cleaning Instructions

Keep your kart clean. With a clean rag, wipe off dirt and oil from around controls. Wipe off any spilled fuel and oil. Keep the engine clean of foreign objects, and be sure to check that air intake fan is free of debris for proper cooling.

F. Kart Lubrication

Lubricate vehicle every 90 days of use. Lubrication should be done sooner, if kart is used everyday.

G. Chain Lubrication

To increase chain life, it should be lubricated with a spray on type chain lubricant.

(See Fig. 10)

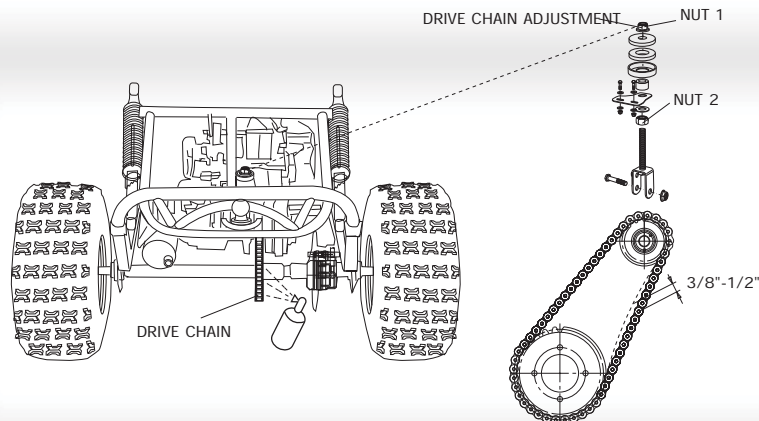

Figure 10

SERVICE INSTRUCTIONS

H. Chain Adjustment

Check the chain adjustment after first two hours of use. Readjust if it has more than 1/2" flex.

- a. Loosen Nut #1
- b. Adjust Nut #2. Turn Nut #2 clockwise in 1/2 turn increments, then turn nut #1 until tight.

Follow this procedure until chain is at proper tension (See Fig. 10).

- c. Repeat the above two steps until chain is adjusted to desired fit.

I. Adjustment of Front And Rear Shock

There are five adjustable positions on each shock. The default position is in the middle set by manufacturer (See Fig. 11)

Use a round nut wrench as you adjust the shock, the tension of shock spring will increase as you screw to left, decrease as you screw to right. Adjust according to the weight of the riders.

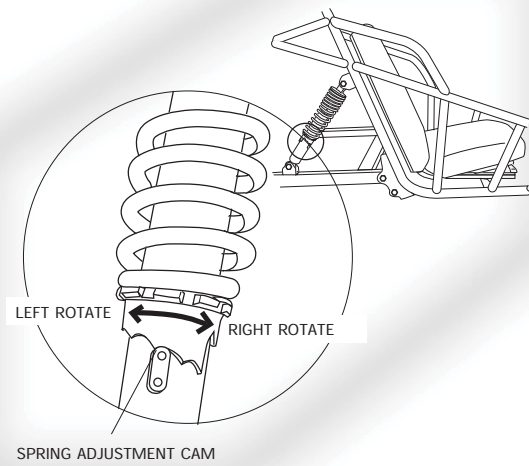

Figure 11

J. Storage Instruction

In the event your kart is not to be operated for a period in excess of 30 days or at the end of each driving season prepare for storage as follows:

- a. Drain fuel tank and carburetor by allowing engine to run out of fuel, and use a fuel stabilizer.
- b. Lubricate engine cylinder by removing the air cleaner, then spray engine fogging oil through the carburetor until motor dies.
- c. Do not save or store gasoline over winter. Using old gasoline, which has deteriorated from storage, will cause hard starting and affect engine performance.

WARNING

Do not drain fuel while engine is hot. Be sure to move Kart outside before draining fuel.

A. Front Wheel Replacement

Do not disassemble the castle nuts when you replace the front wheels.

It is only necessary to remove the 4 lug nuts to remove the wheel. (See Fig. 12)

Tighten the nuts after replacing the wheels.

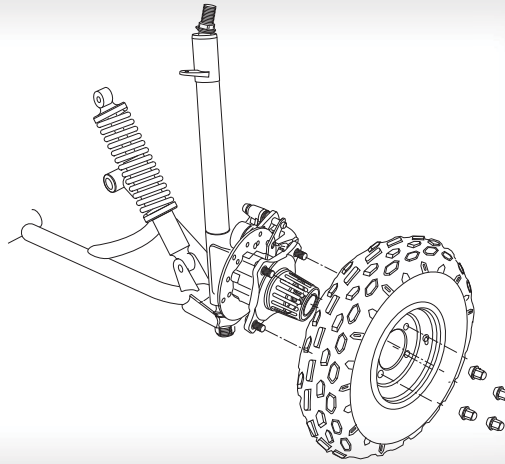

Figure 12

B. Rear Wheel Replacement

Do not disassemble the castle nuts when you replace the rear wheels and hub assembly.

Remove the cotter pin and then 24mm nut. Then slide off wheel and hub assembly.

It is only necessary to remove the 4 lug nuts to remove the wheel by itself. (See Fig.13)

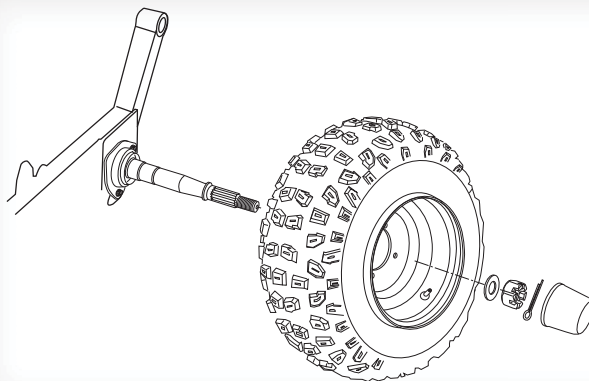

Figure 13

C. Front Wheel Alignment

a. The front wheels should be “toe-in” from 1/8” to 1/4”. To check for alignment, measure distance A and B between the centerline (CL) of the wheels. The proper toe-in dimension A should be 1/8” – 1/4” greater than dimension B.

b. To adjust the alignments, loosen the lock nuts on both sides of Front Tie Rods. To make Dimension B smaller, turn the rod to left. Adjust the rod to right direction to make Dimension B larger. After adjusting to the desired length, tighten the lock nut against the rod end. Recheck the dimensions for proper alignment.

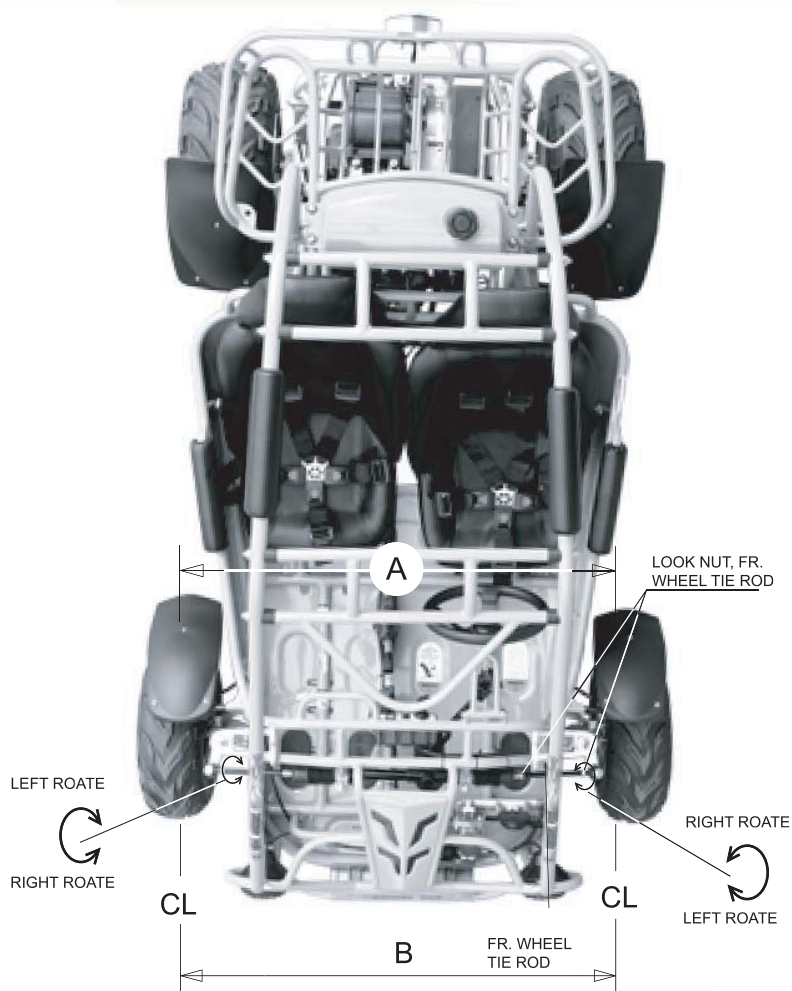

Figure 14

PERIODICAL CHECK AND SERVICES

The maintenance intervals in the following table are based upon average driving conditions. Driving in unusually dusty areas, require more frequent servicing.

Items	odometer	Initial service (300km)	1000km	3000km	10000km
Tire pressure/wear		I	I		
Brake performance		I	I		
Tightness of screws		I	I		
Air cleaner				C	I
Carburetor		I	A		C
Spark plug				C, A	
Drive chain		I	I	C, A, L	
Brake oil				I	
Replace gearbox oil			I	R	
Chassis			C, I	L	
Fuel switch/fuel tank			I		C
Battery				I	
Valve clearance of engine				A	

A: adjust **C:** clean **I:** inspect, clean or replace if necessary. **L:** lubricate **R:** replace

WIRING DIAGRAM

